

(a) 2-Lead Arrangement

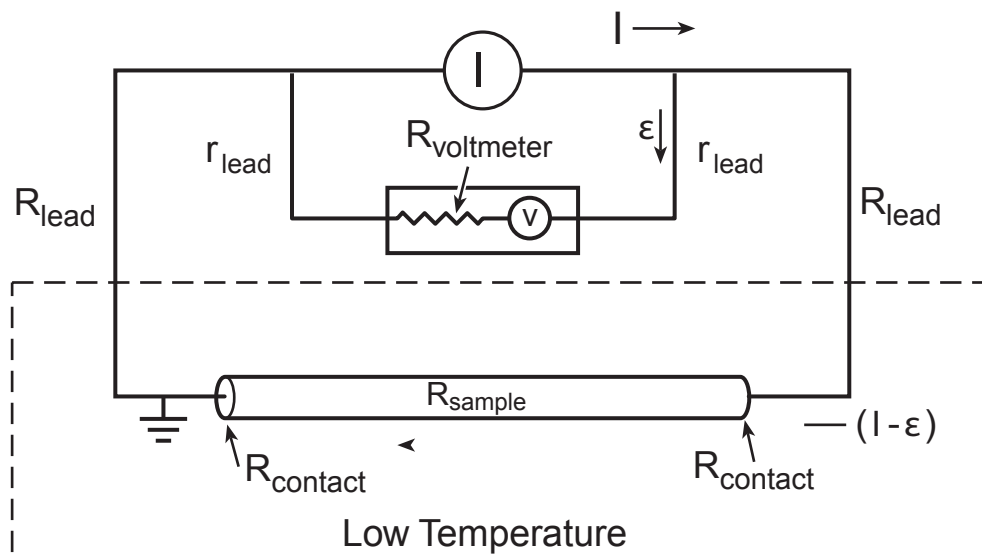

(b) 4-Lead Arrangement

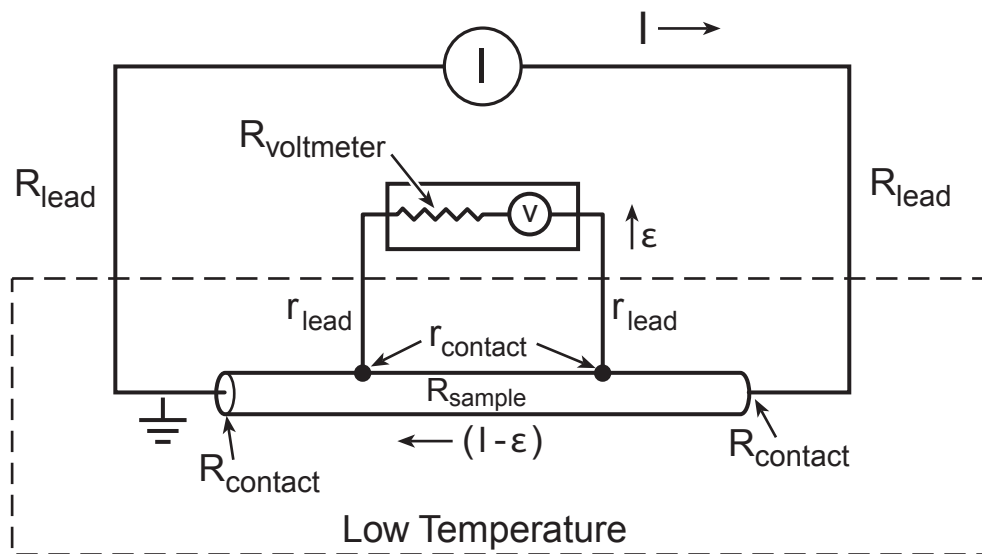

FIG. 7.2 (a) Two-lead arrangement and (b) four-lead arrangement for measuring transport properties.